

518. *Liquid Metals. Part V.* The Role of Oxide Films in the Wetting of Iron, Cobalt, and Nickel by Liquid Sodium, and by Solutions of Barium and Calcium in Liquid Sodium.*

By C. C. ADDISON, E. IBERSEN, and J. A. MANNING.

Receding contact angles for liquid sodium on iron, cobalt, and nickel surfaces in a pure argon atmosphere have been studied as a function of time and temperature. All observations can be correlated on the basis that the changes in contact angle reflect the reduction, by sodium, of the invisible oxide film present on the transition-metal surfaces after abrasion to a mirror surface in air. Nickel carries only one oxide, irrespective of temperature, and wetting rates vary uniformly with temperature. The oxide films on iron and cobalt change at about 225° and 250–300°, respectively, and wetting rates also change abruptly at these temperatures. Each metal possesses a critical wetting temperature (Fe 140°, Co 190°, Ni 195°) below which no wetting occurs, and below which it is believed that no reduction of the oxide film is possible. Addition of small quantities of calcium (>0.07%) or barium to liquid sodium influences wetting rates profoundly.

WHEN liquid sodium is brought into contact with the surface of a solid metal in an inert-gas atmosphere, its behaviour (as determined by the contact angles set up) is reproducible with respect to both temperature and time. In general, contact angles decrease with time, at rates which increase at higher temperatures. The wetting of many of the transition metals by liquid sodium has now been studied in detail in order to elucidate the factors responsible for contact-angle changes, and because these systems are directly relevant to the operation of the sodium-cooled fast nuclear reactors. Some aspects of the work have already been discussed; Parts I¹ and II² recorded measurements of the surface tension of liquid sodium against pure argon, and the variation in this tension produced by the presence of soluble sodium oxide films was shown, in Part III,³ to be so small that the observed changes in contact angle against a solid metal cannot be attributed to this factor. The study of the zinc–liquid sodium system (Part IV⁴) gave the first indication that surface films on the solid metal could play the predominant role. Zinc surfaces electropolished in an alcohol–phosphoric acid solution carry an invisible film of zinc phosphate about 50 Å thick; these surfaces show a critical wetting temperature of 160°, which coincides with the temperature at which liquid sodium reacts with zinc phosphate. When abraded to a high gloss in air, most of the transition-metal surfaces carry an invisible film of oxide, and reaction of liquid sodium with this film was considered to be of possible importance in the wetting of abraded zinc.⁴ The film produced on a copper surface freshly abraded in the atmosphere consists of cuprous oxide,⁵ and the wetting of copper has been interpreted in terms of reaction of sodium with the cuprous oxide film.⁶

On this limited evidence, it appeared that the various wetting processes observed with transition-metal surfaces abraded in air might be explained on the basis of two simple assumptions, (a) that, in the absence of any film, pure sodium would always spread to give a zero contact angle θ on a pure solid metal⁷ and (b) that the observed changes in θ with time and temperature were direct manifestations of the rate and the nature of the chemical reaction between liquid sodium and the oxide film. A detailed study of the

* Part IV, *J.*, 1956, 1454.

¹ Addison, Kerridge, and Lewis, *J.*, 1954, 2861.

² Addison, Addison, Kerridge, and Lewis, *J.*, 1955, 2262.

³ Addison, Addison, and Kerridge, *J.*, 1955, 3047.

⁴ Addison, Addison, Kerridge, and Lewis, *J.*, 1956, 1454.

⁵ Matyas, *Czechoslov. J. Phys.*, 1954, **4**, 174.

⁶ Addison and Kerridge, *Proc. 16th Congr. I.U.P.A.C.*, Paris, 1957 (Sect. de Chimie Minerale), p. 145.

⁷ Bondi, *Chem. Rev.*, 1953, **52**, 418.

wetting of twelve transition metals has confirmed the estimate that all observations can be correlated on this basis. Iron, cobalt, and nickel are compared in the present paper, and later papers will treat the wetting of other transition metals from this point of view.

EXPERIMENTAL

Preparation of Plates.—Iron, cobalt, and nickel were used in the form of thin plates (approx. $4 \times 2 \times 0.05$ cm.) prepared from spectroscopically pure metals (Johnson Matthey Ltd.) containing <16 p.p.m. of other elements. Each plate was abraded with grades 2/0, 3/0 and 4/0 emery paper in turn, and polished with Selvyt cloth, to produce a mirror surface. After polishing, the plate was degreased with redistilled acetone for 12 hr. in a Soxhlet extractor. The plate was removed from the hot acetone, and dried in a current of air at 50° for 2 min. It was then transferred to the contact-angle apparatus (Fig. 1) and had no further contact with the atmosphere. This treatment was standard for all plates, and the reproducibility of wetting times, etc., indicated that the metal surfaces produced must also be fairly standard. It should be stressed that these experiments were designed to study the role of the thin (*ca.* 50 Å) oxide films produced under such conditions; techniques (*e.g.*, ion bombardment) which are available for the partial or even complete removal of oxide films may also distort the surface structure of the metal, and such surfaces have not been examined in this work.

Contact Angles.—These were determined by the vertical plate technique, in an argon atmosphere. The metal plate was suspended from an arm attached to a torsion wire, and was partly immersed in liquid sodium. The forces acting on the plate include the surface tension of sodium (γ) acting at the contact angle θ , and the term $\gamma \cos \theta$ is evaluated from the balance of forces. The surface tension is unchanged throughout the experiments since the solubility of iron, cobalt, and nickel in liquid sodium⁸ is negligible, so that θ is available directly. The apparatus and procedure were as described in Part I, except for that part of the apparatus containing the liquid sodium, which has been modified in several important respects and is shown in Fig. 1. Purified sodium passed, under argon pressure, through the glass sinter A which was controlled at 110° to reduce the Na_2O content of the liquid sodium to <0.002%.⁸ The glass vessel E which was surrounded by furnace F contained an inner vessel B of stainless steel. Liquid sodium begins to penetrate Pyrex glass above 250° , but when the sodium was contained in B, temperatures up to 350° could be used. Temperature was controlled by thermocouple C immersed in the liquid sodium. When solutions of calcium or barium in sodium were used, a stainless steel wire D was also incorporated to stir the liquid metal. To determine the depth of immersion of the plate in the liquid, the optical lever associated with the torsion wire¹ was used. The vertical position of the plate is recorded directly on the optical scale, which was calibrated for this purpose. By noting the position on the optical scale at which the plate first touched the liquid, depths of immersion at any stage were available.

Purity of Materials.—Sodium was purified as already described.¹ The value quoted in Part I for calcium content (0.069%) is too high; analyses of samples of sodium taken after the final filtration gave 0.028% of calcium. High purity of the argon gas used is of first importance if contamination of the liquid sodium surface is to be prevented. Treatment of the argon stream with calcium metal, followed by sodium-potassium alloy, has been abandoned in favour of molecular sieves; their use in maintaining clean surfaces on liquid sodium has been fully described elsewhere.⁹

RESULTS AND DISCUSSION

The results in Figs. 2—5 refer to receding contact angles. For each metal at each temperature, the plate of metal was first half immersed in liquid sodium, then drawn upwards through the surface in steps of about 1 mm. at a time. At each step the contact angle was recorded. Fig. 2 shows the results obtained for cobalt plates at 250° . At selected periods after initial immersion, the plate was drawn through the surface and contact angles represented by points on curves A—E were obtained, in that order. When the plate had been raised about 5 mm. through the surface, the contact angle became

⁸ Liquid Metals Handbook, Sodium—NaK Supplement, TID 5277, Chapter 1; U.S. Govt. Printing Office, 1955.

⁹ Addison, Ibersen, and Raynor, *Chem. and Ind.*, 1958, 96.

independent of further movement of the plate, and the final curve E represents the true receding angle-time relationship. For each metal, there is a critical temperature (see below) above which θ always falls eventually to zero, and consideration will be restricted initially to the temperature ranges above the critical temperature. Altogether 11 such experiments were carried out with iron plates, 13 with cobalt plates, and 5 with nickel plates, and Fig. 2 is typical of the type of behaviour observed. The rate at which θ falls to zero is influenced profoundly by temperature; this is illustrated in Fig. 3 which shows θ -immersion time curves (each derived as was curve E, Fig. 2) for pure iron in sodium at several temperatures. A corresponding family of curves was obtained for cobalt and nickel also.

The results for all three metals are collected in Fig. 4. Here we have taken the times for complete wetting (T_w) to be a measure of the rate of the surface reaction, and $\log T_w$ is plotted in Fig. 4 against the inverse of the absolute temperature. The surface reaction

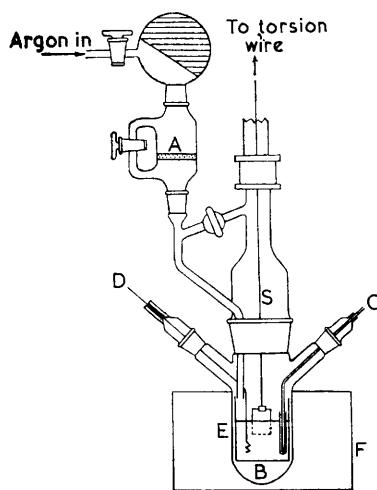

FIG. 1. Apparatus. (For key see text.)

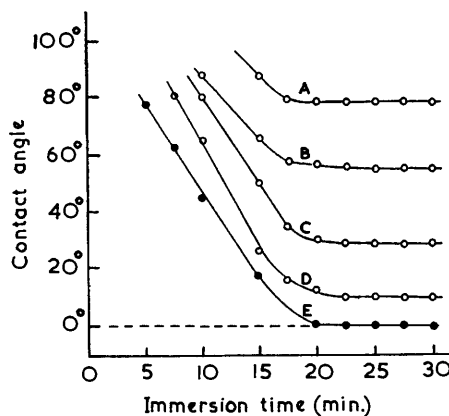

FIG. 2. Receding contact angles for liquid sodium on cobalt at 250°. Distances through which the cobalt plate was raised through the liquid surface were: A, 1; B, 2; C, 3; D, 4; E, 5–10 mm.

is not a reversible one, and the lines in Fig. 4 are not to be regarded as real Arrhenius plots; nevertheless, this method of correlating the results is of considerable value. With many transition metals, it is found that a single straight line is obtained in cases where the same surface oxide is present at all temperatures. When the surface oxide undergoes change at a certain temperature, this is reflected by a break in the $\log T_w - 1/T$ plot at that temperature. Indeed, we believe that wetting by liquid sodium represents one of the most sensitive techniques available for the study of changes in oxide films with temperature.

Nickel.—Study of the nickel metal surface¹⁰⁻¹² by electron diffraction has confirmed the finding that the oxide NiO is the only oxide present at the surface at temperatures up to 500°. The specimens used by Gulbransen and Hickman¹² were prepared in a manner very similar to that used in this work. If the reduction of the oxide NiO by sodium is very responsible for wetting, then the same process $\text{NiO} + 2\text{Na} \rightarrow \text{Ni} + \text{Na}_2\text{O}$ occurs throughout the temperature range. This reaction is acceptable thermodynamically, since the values of $-\Delta G_{298}$ for Na_2O and NiO are 89.9 and 51.7 kcal./mole, respectively.¹³ In many

¹⁰ Preston, *Phil. Mag.*, 1934, **17**, 466.

¹¹ Darbyshire, *Trans. Faraday Soc.*, 1933, **21**, 657.

¹² Gulbransen and Hickman, *Trans. Amer. Inst. Min. Met. Engrs.*, 1947, **171**, 641.

¹³ "Selected Values of Chemical Thermodynamic Properties," Nat. Bureau Standards Circ. 500, Washington, D.C., 1952.

cases (e.g., silver oxide¹⁴) the physical properties of bulk and surface oxides can vary widely, but with nickel oxide it is relevant that the heat of formation $-\Delta H$ for the bulk oxide, 58.0 kcal./mole, is near to the heat of chemisorption of oxygen on nickel at 573° K (55.4 kcal./mole).¹⁴ Consistently with the above, we find that the $\log T_w - 1/T$ results (Fig. 4) for nickel lie on a single straight line.

Cobalt.—In contrast to nickel, the oxide present on the surface of cobalt metal abraded in air varies with temperature. The film is to some extent a multiple one,^{15, 16} but the oxide CoO is predominant below 300°, and Co₃O₄ predominant above 300°. Gulbransen and Hickman¹² were unable to identify the oxide Co₂O₃ by X-ray or electron-diffraction techniques, though its presence at temperatures below 300° has been inferred by Valensi.¹⁵ The bulk oxide Co₂O₃ is transformed¹⁷ into Co₃O₄ in the temperature range 240—300°.

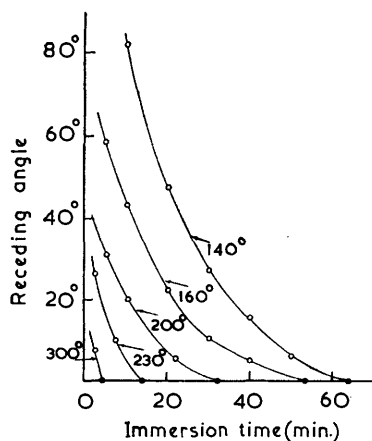

FIG. 3. Wetting of pure iron by sodium.

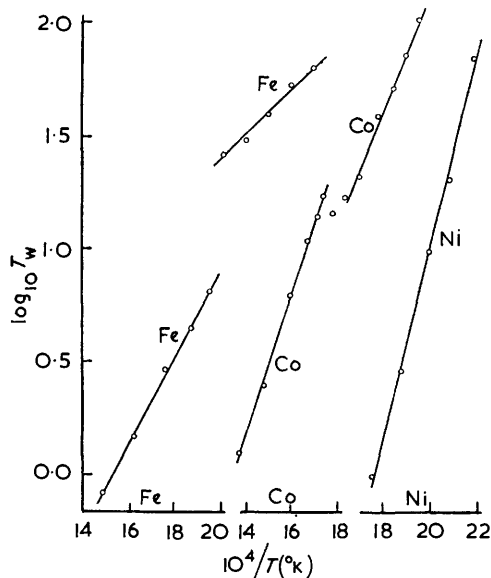

FIG. 4. Influence of temperature on times for complete wetting by liquid sodium.

It is clear from these observations that there is a change in the composition of the film at 300°, and the $\log T_w - 1/T$ plot for cobalt (Fig. 4) shows two distinct parts, with a discontinuity in the temperature range 260—300°. Each part is a straight line, but the slopes differ and this is attributed to different surface reactions. Below 260°, wetting by sodium occurs as a result of reduction of the oxide CoO (with perhaps some Co₂O₃); above 300°, it is the oxide Co₃O₄ which is reduced by sodium. Each reduction process is acceptable in terms of the free energies of formation, since $-\Delta G_{298}$ for the oxides CoO and Co₃O₄ are 51.6 and 45.5 kcal./mole, relative to one g.-atom of oxygen.¹⁸

Iron.—The $\log T_w - 1/T$ plot for iron (Fig. 4) again falls into two parts which are more clearly distinguished than with cobalt, and it has been possible to narrow the transition temperature range to 220—240°. This agrees remarkably well with observed changes in the composition of the oxide film. In the low-temperature range the film consists of the oxides α -Fe₂O₃, γ -Fe₂O₃, and Fe₃O₄.^{12, 19, 20} For thick or thin films, the transition γ -Fe₂O₃

¹⁴ Gonzalez and Parravano, *J. Amer. Chem. Soc.*, 1956, **78**, 4533.

¹⁵ Valensi, *Métaux et Corrosion*, 1950, **25**, 283.

¹⁶ Arkharov and Lomakin, *J. Tech. Phys. Moscow*, 1944, **14**, 155.

¹⁷ Rotinyan and Ovchinnikova, *Doklady Akad. Nauk S.S.S.R.*, 1955, **100**, 471.

¹⁸ Coughlin, U.S. Bureau Mines, Bull. 542, 1954.

¹⁹ Trillat, *Rév. Mét.*, 1956, **53**, 497; Davies and Evans, *J.*, 1956, 4373; Nelson, *J. Chem. Phys.*, 1938, **6**, 606.

²⁰ Vernon, Calnan, and Nurse, *Proc. Roy. Soc.*, 1953, **A**, **216**, 375.

to $\alpha\text{-Fe}_2\text{O}_3$ occurs at 225° . With thin films, the transition $\alpha\text{-Fe}_2\text{O}_3$ to Fe_3O_4 also occurs at 225° , but the transition temperature increases with film thickness.¹² Vernon *et al.*²⁰ also reported the presence of $\gamma\text{-Fe}_2\text{O}_3$ on iron at low temperatures and observed its direct conversion into Fe_3O_4 in thin films at a critical temperature near 225° . In view of this, we consider that wetting by sodium below 220° involves reduction of a film consisting of $\alpha\text{-Fe}_2\text{O}_3$, $\gamma\text{-Fe}_2\text{O}_3$, and Fe_3O_4 , and that above 240° wetting rates depend upon reduction of a film containing Fe_3O_4 only. The values of $-\Delta G_{298}$ for Fe_2O_3 and Fe_3O_4 are 59.1 and 60.8 kcal./mole, relative to one g.-atom of oxygen.¹⁸

Mechanism of Wetting by Sodium.—The above results give some of the evidence pointing to the important role played by oxide films, and it is now relevant to consider the mechanism by which the receding contact angle changes from its initial high value to zero (as shown, for example, for iron in Fig. 3). When the solid metal is first immersed in liquid sodium, the latter is in contact with a continuous oxide film; this explains the initial high value of θ , since contact angles for liquid metals against oxides are usually high.^{7, 21, 22} The rate of reduction in the film cannot be inferred directly from corresponding bulk oxide reactions since the influence of the solid metal substrate is unknown, but the significant feature is that the change in θ with time at any given temperature is gradual, and there is no sign of any sharp discontinuity in the rate of change of θ . This suggests

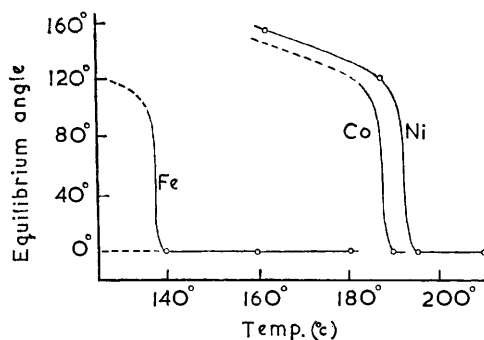

FIG. 5. Critical wetting temperatures.

that there is a single rate-determining step, and two possible mechanisms have been considered. First, reduction may occur completely and immediately on immersion. This would leave a film of sodium oxide at the solid metal surface, in which case the subsequent wetting would reflect the rate of desorption of sodium oxide into the liquid sodium. This is known to be slow where solubility of the solute is low, and to be highly temperature-dependent. However, there is nothing in this mechanism which can explain either the results shown in Fig. 4, or the critical wetting phenomenon discussed below. The alternative mechanism, in which reduction of the oxide film by sodium is sufficiently slow to be the rate-determining step, is the one assumed to be correct in the above interpretations of the wetting of iron, cobalt, and nickel. Slow reduction will produce atoms of these metals on the surface, and nucleation of these atoms presents a clean surface which will be wetted by sodium. As reduction proceeds, the proportion of the surface which consists of metal rather than oxide will increase and the mean observed value of θ will fall. Reduction rate will depend on temperature and on the particular oxide present at the surface.

Critical Wetting Temperatures.—All results discussed so far refer to higher temperature ranges, for which θ eventually falls to zero. With each metal, however, there is a characteristic temperature below which this no longer occurs, and the critical nature of the change is shown in Fig. 5. With nickel, for example, the equilibrium value of θ is zero at all temperatures above 195° ; the behaviour changes sharply within a few degrees, and at lower temperatures θ exceeds 90° . Iron and cobalt show the same phenomenon, but at

²¹ Taylor, *J. Nuclear Energy*, 1955, **2**, 15.

²² Bradhurst and Buchanan, *Austral. J. Chem.*, 1961, **14**, 397.

critical temperatures of 190° and 140°, respectively. The high equilibrium contact angle below the critical temperature is typical of a metal oxide in contact with liquid sodium of low oxygen content.²² Accepting that the solid metal substrate is able to influence the chemical as well as the physical properties of a thin oxide film, we consider that no reduction of the oxide film occurs below the critical temperature, and that the latter is characteristic of the chemistry of films of this type. The results for nickel in Fig. 5 are supported by the observations of Winkler and Vandenberg²³ who determined the electrical resistance of ribbons of nickel immersed in liquid sodium. When wetting occurred, the interfacial resistance was reduced and the sodium acted as a conductor in parallel with the ribbon; with nickel carrying an oxide film, the wetting temperature was found to be 180–190°.

Wetting by Solutions of Calcium or Barium in Sodium.—It was to be expected that, if the wetting process involves oxide-film reduction, the presence of metals dissolved in the sodium which have a greater oxygen affinity than sodium itself would accelerate wetting. Values of $-\Delta G_{298}$ for CaO, BaO, and Na₂O are 143.3, 126.5, and 89.9 kcal./mole, respectively, and the addition of small quantities of calcium and barium to the sodium has been found to influence wetting rates profoundly. The alternative explanation of this, *i.e.*, that the addition of calcium or barium to liquid sodium makes a significant difference to the surface tension of liquid sodium, has been dismissed by a separate study of these solutions which will be reported in a later paper. Solutions of these metals were filtered into the stainless steel beaker (Fig. 1), and the calcium or barium content determined by analysis of samples drawn from the beaker. The rates of wetting of nickel and iron by calcium solutions are compared in the Table with the rates for sodium alone. The behaviour of barium solutions was very similar to that of the calcium solutions, and the barium-sodium system was not studied quantitatively.

With iron plates, solutions containing 0.055% of calcium showed wetting behaviour almost identical with that of sodium alone. There is a threshold concentration of calcium

The wetting of nickel and iron by solutions of calcium in sodium.

Solid metal	Wt. % of Ca in Na	Temp.	Equilibrium angle θ		Immersion time (min.) for $\theta \rightarrow 0^\circ$		
			in soln.	in pure sodium	in soln.	in pure sodium	
Nickel	0.062	140°	>90°	>90°	—	—	
		160	>90	>90	—	—	
		180	>90	>90	—	—	
		200	0	0	29	31	
	0.095	160	0	>90	Immediate *	—	
		200	0	0	Immediate	31	
		250	0	0	Immediate	4.5	
		0.252	230	0	0	Immediate	10
			250	0	0	Immediate	4.5
		300	0	0	Immediate	Immediate	
Iron	0.055	140	0	0	65	63	
		200	0	0	30	33	
		220	0	0	28	26	
	0.082	150	0	0	Immediate	55	
		200	0	0	Immediate	33	
		250	0	0	Immediate	6	
		0.199	200	0	0	Immediate	33
			240	0	0	Immediate	7
		280	0	0	Immediate	4	

* The term "Immediate" indicates that the contact angle fell to 0° within the time (about 1 min.) required to take the first measurement.

of about 0.07 wt.-% below which calcium does not influence wetting by sodium, but above this concentration its effect is very marked; plates which required almost an hour to be wetted by sodium alone were wetted immediately by sodium containing 0.082% of calcium.

²³ Winkler and Vandenberg, U.S.A.E.C. Rep. KAPL-P-231, 1949.

The "pure" sodium used in this work contained 0.028% of calcium, and the Table confirms the view that this quantity of calcium impurity has no effect on its wetting properties. It was at first sight surprising that the critical wetting temperature found for calcium solutions agreed with the temperature, 140°, found for sodium alone. However, the solubility of calcium in sodium²⁴ falls to 0.063% at 140°; below this temperature its concentration is therefore less than that required to influence wetting, so that it is not possible to study the effect of calcium on the critical temperature for iron. Observations with nickel plates were similar (Table), but the critical temperature for nickel is higher (195°) and at this temperature the solubility of calcium is above the threshold level. A solution containing 0.095% of calcium reduces the critical temperature for nickel from 195° to lower than 160°, which supports the postulate that the critical temperature is that below which reduction of the oxide film cannot occur.

The authors are indebted to the Director, Atomic Energy Research Establishment, Harwell, for financial assistance in support of this work.

THE UNIVERSITY, NOTTINGHAM.

[Received, February 13th, 1962.]

²⁴ Gilbert, *Chem. Eng. News*, 1948, **26**, 2064; Rinck, *Compt. rend.*, 1933, **197**, 49.
